

Produced Water Treatment San Ardo, California

Key figures

➤ 50,000 barrels per day of treated water for discharge



Site Overview



Double-pass Reverse Osmosis System



High-rate Downflow Multimedia Filters

N.A. Water Systems, LLC
water.info@veoliawater.com
www.nawatersystems.com
800-337-0777

The client

Chevron U.S.A. Inc., a fully-owned subsidiary of Chevron Corporation, is one of the world's leading energy companies. Chevron subsidiaries conduct business in approximately 180 countries around the world, producing and transporting crude oil and natural gas, and refining, marketing and distributing fuels and other energy products.

Client's needs

The San Ardo project involves treatment of produced water for the purposes of discharge to recharge basins and production of Once Through Steam Generator (OTSG) make-up water. The raw produced water temperature is 200°F, and it contains about 25 ppm free oil, 80 ppm TOC, 240 ppm silica, 26 ppm boron, 240 ppm hardness and 6,500 ppm Total Dissolved Solids (TDS). The project goal was to reduce the feed water TDS to less than 510 ppm and boron to less than 0.64 ppm for recharge basins discharge, while achieving 75% water recovery across the treatment system and minimizing the volume of produced water requiring re-injection. For the purpose of OTSG make-up, the project goal was to reduce the feed water hardness to less than 2 ppm as CaCO₃.

Our solutions

The treatment process includes a common pretreatment step for free oil removal followed by OPUS™ technology (patent pending) to achieve the discharge water quality and a Series Softening System for generation of OTSG make-up water. The free oil removal system consists of an induced gas flotation system and a PowerClean walnut shell filtration system to reduce the free oil to less than 0.5 ppm. The OPUS™ technology consists of multiple treatment steps such as heat exchange, degasification, chemical softening, media filtration, ion exchange softening, and a double-pass RO system to meet the effluent water quality requirements. The solids generated from the system are dewatered and disposed in a landfill. The Series Softening System involves two-stage strong acid cation softeners to reduce the hardness in the feed water to achieve the water quality specification.

Produced Water Treatment San Ardo, California

Scope of Work and Technologies

The San Ardo project involved process design, basic engineering, equipment procurement, and construction management. The advanced water treatment system includes the equipment shown in the process diagram below and is operated by Veolia Water North America.

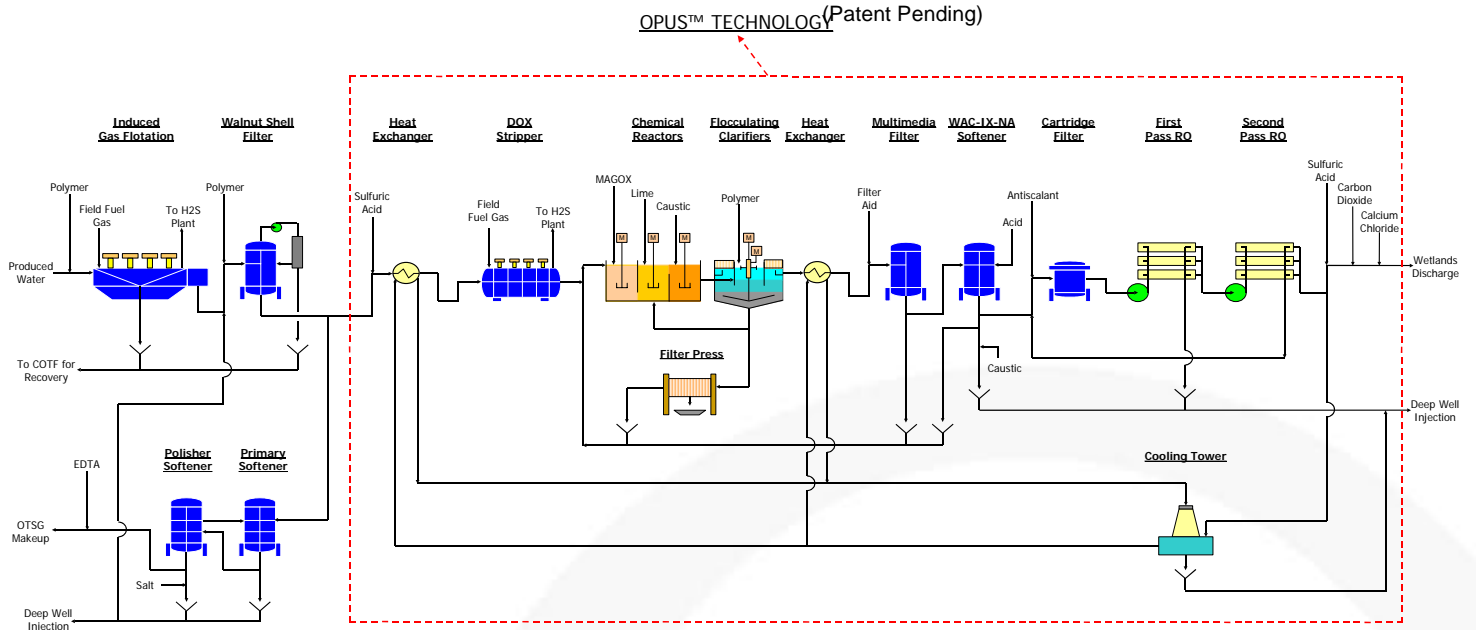

Performance Data*

CONSTITUENT	PRODUCED WATER	DOUBLE PASS RO PERMEATE	FINAL TREATED EFFLUENT	EFFLUENT SPECIFICATION
TDS, PPM	6,500	76	120	510
SODIUM, PPM	2,300	43	43	85.0
CHLORIDE, PPM	3,400	Non-Detect	11	127.5
SULFATE, PPM	133	Non-Detect	120	127.5
NITRATE, PPM	10.0	Non-Detect	Non-Detect	4.25
BORON, PPM	26.0	0.24	0.24	0.64
pH, S.U.	7.5	10.7	7.0	6.5 – 8.4

*Based on initial 12 months of operation